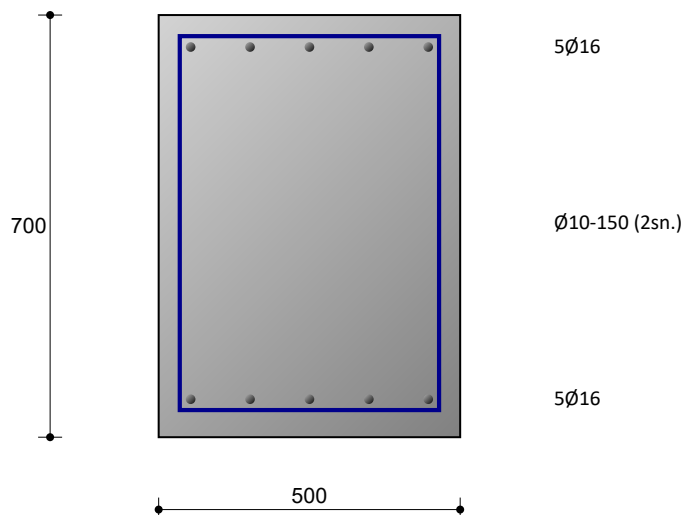

ALGEMEEN

Bestand :Struct4U\website\voorbeeld uitdraai\XConstructVoorbeeldenDutch.xcst

Gevolgklasse : CC2

BETONDOORSNEDE: Betondoorsnede**INVOERGEGEVENS****Betondoorsnede**

Elementtype	Balk	Constructieklasse S4
Prefab	nee	
Betonsterkteklasse	C20/25	Kruipcoëfficiënt 2,70
Betonstaalsoort	B500B	
Korrel diameter	31,5 mm	
Milieuklassen	Bovenzijde XC4	Onderzijde XC4, XD2 → XD2
Betonoppervlak	Controleerbaar	Controleerbaar
ΔC_{dev}	5 mm	
Dekking	35 mm	45 mm
Nominale dekking c_{nom}	35 mm	45 mm
		EN 1992-1-1 (4.1)
Aantal beugelsneden	2	Hoek betondrukdiagonaal 40
N_{Ed}	0 kN	
M_{Ed}	150 kNm	
V_{Ed}	100 kN	
T_{Ed}	30 kNm	
N_k	0 kN	
M_k	122 kNm	

BEREKENING volgens Eurocode 2

Gehanteerde normen: : NEN-EN 1992-1-1+C1:2011/NB:2016+A1:2020 nl

Hoofdstuk 6 Uiterste grenstoestanden (UGT)

6.1 Buiging met of zonder normaalkracht

$$M_{Ed} = 150,00 \text{ kNm} < M_{Rd} = 264,25 \text{ kNm} \quad (\text{u.c.}=0,57)$$

$$x_{u,max} = \frac{\delta - k_1}{k_2} d = \frac{1 - \frac{435}{500 + 435}}{1,00} d = 0,535 \times 637 = 340,7 \text{ mm} \quad \dots(5.10a)$$

$$x_u = 63,7 \text{ mm} < x_{u,max} = 340,7 \text{ mm}$$

M-N-Kappa - diagram - UGT

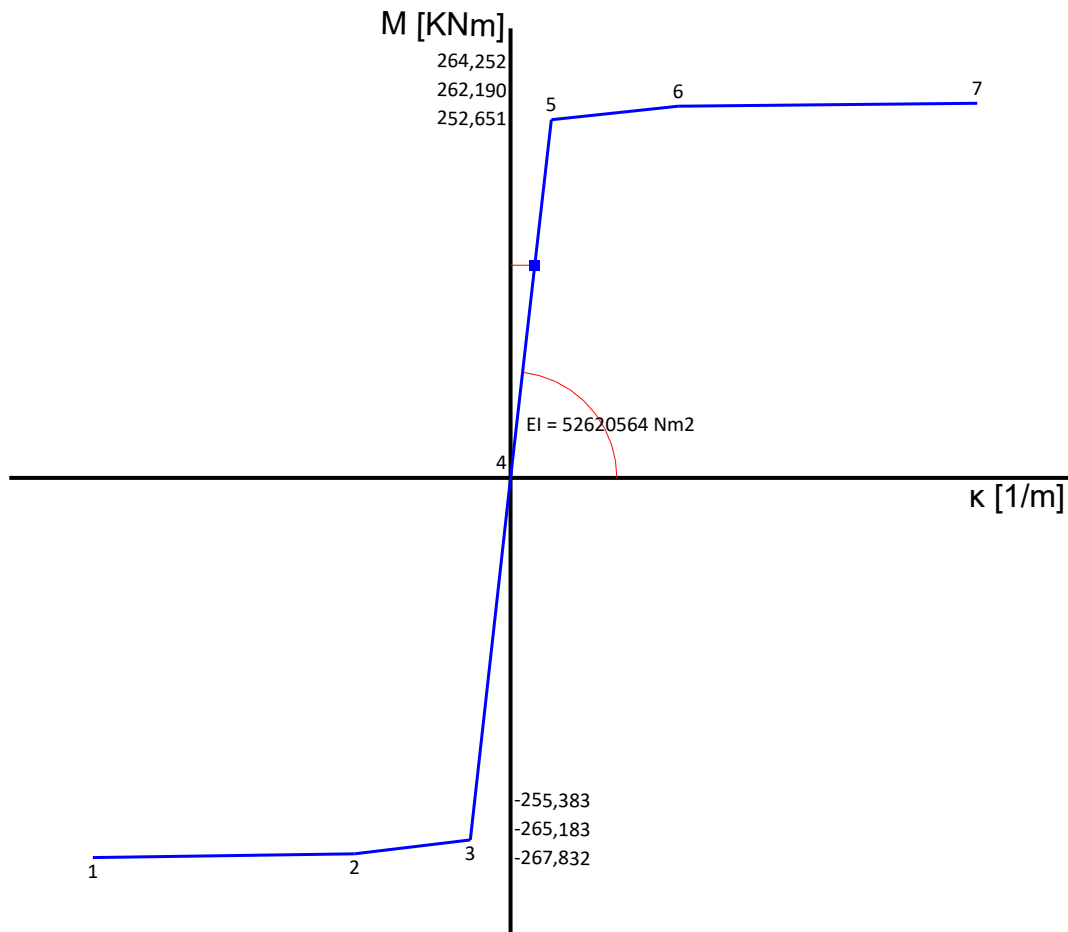

Punt [mm]	z' [mm]	Δε [o/oo]	Δσs [N/mm ²]	x [mm]	εBoven [o/oo]	εOnder [o/oo]
1:εc=εcu3	-700,0	-3,500	-13,3	71,2	30,909	-3,500
2:εc=εc3	-700,0	-1,750	-13,3	95,3	11,100	-1,750
3:σ=fy	-53,0	2,174	434,8	187,9	2,425	-0,889
4:	0,0	0,000	0,0	0,0	0,000	0,000
5:σ=fy	-637,0	2,174	434,8	184,2	-0,885	2,476
6:εc=εc3	0,0	-1,750	-13,3	88,7	-1,750	12,066
7:εc=εcu3	0,0	-3,500	-13,3	63,7	-3,500	34,945

Punt	My [kNm]	Mz [kNm]	α [°]	κ [1/m]	Ely [Nm ²]	E [N/mm ²]	d [mm]
1:εc=εcu3	-267,832	0,000	0,0	-49,2	5448720	357	647,0
2:εc=εc3	-265,183	0,000	0,0	-18,4	14445549	946	647,0
3:σ=fy	-255,383	0,000	0,0	-4,7	53939175	3534	647,0
4:	0,000	0,000	0,0	0,0	0	0	0,0
5:σ=fy	252,651	0,000	0,0	4,8	52620564	3447	637,0
6:εc=εc3	262,190	0,000	0,0	19,7	13284275	870	637,0
7:εc=εcu3	264,252	0,000	0,0	54,9	4811435	315	637,0

$$EI = \frac{M_{Ed}}{\kappa} = \frac{150,00 \times 10^3}{2,9} = 52620564 \text{ Nm}^2 \quad E = 3447 \text{ N/mm}^2$$

Doorsnedeberkening

$$\epsilon_c = \epsilon_{cu3}$$

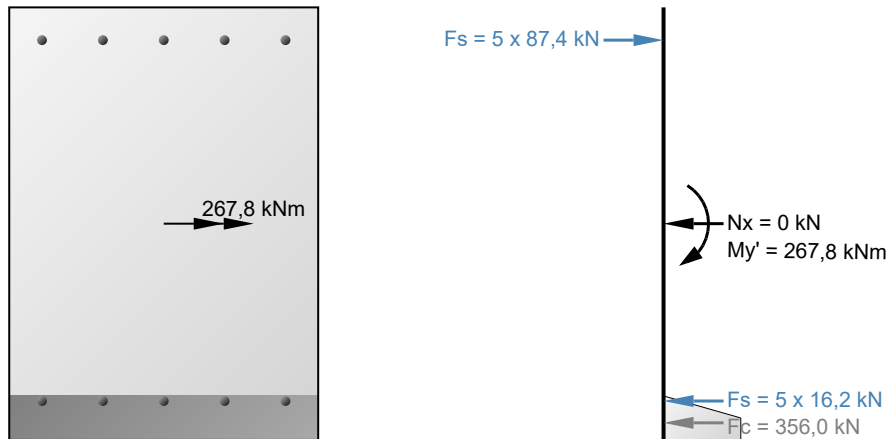

Hoek buigingsas en neutrale lijn $\alpha = 0,000^\circ$; $x_u = 71,2 \text{ mm}$; $d = 647,0 \text{ mm}$
 Zwaartepunt doorsnede $y' = 0,0$ $z' = -350,0$ ($y = 0,0$ $z = 0,0$)

y' [mm]	z' [mm]	Wap.	A_s [mm ²]	$\Delta\epsilon$ [o/oo]	σ_c [N/mm ²]	$\Delta\sigma_s$ [N/mm ²]
-197,0	-53,0	1Ø16	201	28,303		434,8
-98,5	-53,0	1Ø16	201	28,303		434,8
0,0	-53,0	1Ø16	201	28,303		434,8
98,5	-53,0	1Ø16	201	28,303		434,8
197,0	-53,0	1Ø16	201	28,303		434,8
-197,0	-637,0	1Ø16	201	-0,403		-80,6
-98,5	-637,0	1Ø16	201	-0,403		-80,6
0,0	-637,0	1Ø16	201	-0,403		-80,6
98,5	-637,0	1Ø16	201	-0,403		-80,6
197,0	-637,0	1Ø16	201	-0,403		-80,6
0,0	-700,0			-3,500	-13,3	

y' [mm]	z' [mm]	F_c [kN]	F_s [kN]	dy' [mm]	dz' [mm]	F [kN]	$F \cdot dy'$ [kNm]	$F \cdot dz'$ [kNm]
-197,0	-53,0		87,4	-197,0	297,0	87,4	-17,2	26,0
-98,5	-53,0		87,4	-98,5	297,0	87,4	-8,6	26,0
0,0	-53,0		87,4	0,0	297,0	87,4	0,0	26,0
98,5	-53,0		87,4	98,5	297,0	87,4	8,6	26,0
197,0	-53,0		87,4	197,0	297,0	87,4	17,2	26,0
-197,0	-637,0		-16,2	-197,0	-287,0	-16,2	3,2	4,7
-98,5	-637,0		-16,2	-98,5	-287,0	-16,2	1,6	4,7
0,0	-637,0		-16,2	0,0	-287,0	-16,2	0,0	4,7
98,5	-637,0		-16,2	98,5	-287,0	-16,2	-1,6	4,7
197,0	-637,0		-16,2	197,0	-287,0	-16,2	-3,2	4,7
0,0	-672,3	-356,0		0,0	-322,3	-356,0	0,0	114,7
totaal:						0,0	0,0	267,8

Doorsnedeberekening

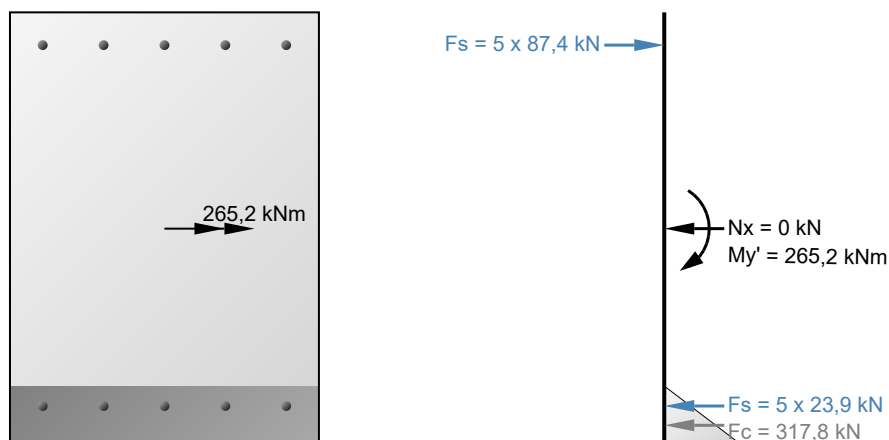
 $\epsilon_C = \epsilon_{C3}$ Hoek buigingsas en neutrale lijn $\alpha = 0,000^\circ$; $x_u = 95,3$ mm; $d = 647,0$ mmZwaartepunt doorsnede $y' = 0,0$ $z' = -350,0$ ($y = 0,0$ $z = 0,0$)

y' [mm]	z' [mm]	Wap.	A_s [mm ²]	$\Delta\epsilon$ [o/oo]	σ_c [N/mm ²]	$\Delta\sigma_s$ [N/mm ²]
-197,0	-53,0	1Ø16	201	10,127		434,8
-98,5	-53,0	1Ø16	201	10,127		434,8
0,0	-53,0	1Ø16	201	10,127		434,8
98,5	-53,0	1Ø16	201	10,127		434,8
197,0	-53,0	1Ø16	201	10,127		434,8
-197,0	-637,0	1Ø16	201	-0,593		-118,7
-98,5	-637,0	1Ø16	201	-0,593		-118,7
0,0	-637,0	1Ø16	201	-0,593		-118,7
98,5	-637,0	1Ø16	201	-0,593		-118,7
197,0	-637,0	1Ø16	201	-0,593		-118,7
0,0	-700,0			-1,750	-13,3	

y' [mm]	z' [mm]	F_c [kN]	F_s [kN]	dy' [mm]	dz' [mm]	F [kN]	$F \cdot dy'$ [kNm]	$F \cdot dz'$ [kNm]
-197,0	-53,0		87,4	-197,0	297,0	87,4	-17,2	26,0
-98,5	-53,0		87,4	-98,5	297,0	87,4	-8,6	26,0
0,0	-53,0		87,4	0,0	297,0	87,4	0,0	26,0
98,5	-53,0		87,4	98,5	297,0	87,4	8,6	26,0
197,0	-53,0		87,4	197,0	297,0	87,4	17,2	26,0
-197,0	-637,0		-23,9	-197,0	-287,0	-23,9	4,7	6,8
-98,5	-637,0		-23,9	-98,5	-287,0	-23,9	2,4	6,8
0,0	-637,0		-23,9	0,0	-287,0	-23,9	0,0	6,8
98,5	-637,0		-23,9	98,5	-287,0	-23,9	-2,4	6,8
197,0	-637,0		-23,9	197,0	-287,0	-23,9	-4,7	6,8
0,0	-668,2	-317,8		0,0	-318,2	-317,8	0,0	101,1
totaal:						0,0	0,0	265,2

Doorsnedeberekening

$\sigma = f_y$

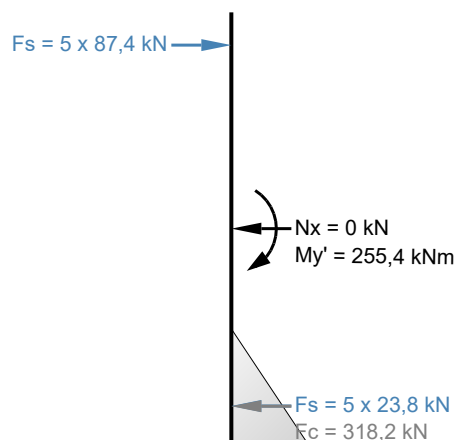
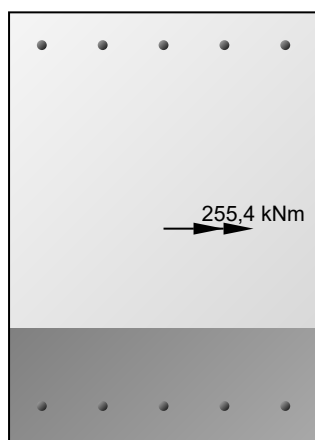

Hoek buigingsas en neutrale lijn $\alpha = 0,000^\circ$; $x_u = 187,9$ mm; $d = 647,0$ mm

Zwaartepunt doorsnede $y' = 0,0$ $z' = -350,0$ ($y = 0,0$ $z = 0,0$)

y' [mm]	z' [mm]	Wap.	A_s [mm ²]	$\Delta\varepsilon$ [o/oo]	σ_c [N/mm ²]	$\Delta\sigma_s$ [N/mm ²]
-197,0	-53,0	1Ø16	201	2,174		434,8
-98,5	-53,0	1Ø16	201	2,174		434,8
0,0	-53,0	1Ø16	201	2,174		434,8
98,5	-53,0	1Ø16	201	2,174		434,8
197,0	-53,0	1Ø16	201	2,174		434,8
-197,0	-637,0	1Ø16	201	-0,591		-118,2
-98,5	-637,0	1Ø16	201	-0,591		-118,2
0,0	-637,0	1Ø16	201	-0,591		-118,2
98,5	-637,0	1Ø16	201	-0,591		-118,2
197,0	-637,0	1Ø16	201	-0,591		-118,2
0,0	-700,0			-0,889	-6,8	

y' [mm]	z' [mm]	F_c [kN]	F_s [kN]	dy' [mm]	dz' [mm]	F [kN]	$F \cdot dy'$ [kNm]	$F \cdot dz'$ [kNm]
-197,0	-53,0		87,4	-197,0	297,0	87,4	-17,2	26,0
-98,5	-53,0		87,4	-98,5	297,0	87,4	-8,6	26,0
0,0	-53,0		87,4	0,0	297,0	87,4	0,0	26,0
98,5	-53,0		87,4	98,5	297,0	87,4	8,6	26,0
197,0	-53,0		87,4	197,0	297,0	87,4	17,2	26,0
-197,0	-637,0		-23,8	-197,0	-287,0	-23,8	4,7	6,8
-98,5	-637,0		-23,8	-98,5	-287,0	-23,8	2,3	6,8
0,0	-637,0		-23,8	0,0	-287,0	-23,8	0,0	6,8
98,5	-637,0		-23,8	98,5	-287,0	-23,8	-2,3	6,8
197,0	-637,0		-23,8	197,0	-287,0	-23,8	-4,7	6,8
0,0	-637,4	-318,2		0,0	-287,4	-318,2	0,0	91,5
totaal:						0,0	0,0	255,4

Doorsnedeberkening

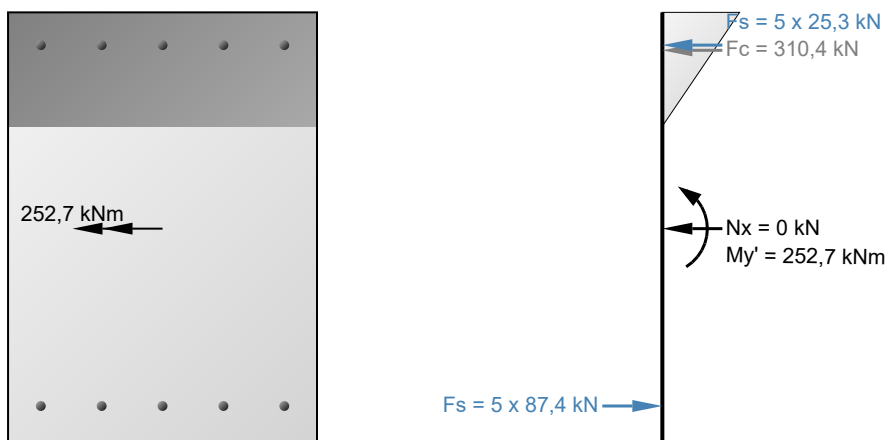
 $\sigma = f_y$ 

Hoek buigingsas en neutrale lijn $\alpha = 0,000^\circ$; $x_u = 184,2$ mm; $d = 637,0$ mm
 Zwaartepunt doorsnede $y' = 0,0$ $z' = -350,0$ ($y = 0,0$ $z = 0,0$)

y' [mm]	z' [mm]	Wap.	A_s [mm ²]	$\Delta\varepsilon$ [o/oo]	σ_c [N/mm ²]	$\Delta\sigma_s$ [N/mm ²]
0,0	0,0			-0,885	-6,7	
-197,0	-53,0	1Ø16	201	-0,630		-126,0
-98,5	-53,0	1Ø16	201	-0,630		-126,0
0,0	-53,0	1Ø16	201	-0,630		-126,0
98,5	-53,0	1Ø16	201	-0,630		-126,0
197,0	-53,0	1Ø16	201	-0,630		-126,0
-197,0	-637,0	1Ø16	201	2,174		434,8
-98,5	-637,0	1Ø16	201	2,174		434,8
0,0	-637,0	1Ø16	201	2,174		434,8
98,5	-637,0	1Ø16	201	2,174		434,8
197,0	-637,0	1Ø16	201	2,174		434,8

y' [mm]	z' [mm]	F_c [kN]	F_s [kN]	dy' [mm]	dz' [mm]	F [kN]	$F \cdot dy'$ [kNm]	$F \cdot dz'$ [kNm]
0,0	-61,4	-310,4		0,0	288,6	-310,4	0,0	-89,6
-197,0	-53,0		-25,3	-197,0	297,0	-25,3	5,0	-7,5
-98,5	-53,0		-25,3	-98,5	297,0	-25,3	2,5	-7,5
0,0	-53,0		-25,3	0,0	297,0	-25,3	0,0	-7,5
98,5	-53,0		-25,3	98,5	297,0	-25,3	-2,5	-7,5
197,0	-53,0		-25,3	197,0	297,0	-25,3	-5,0	-7,5
-197,0	-637,0		87,4	-197,0	-287,0	87,4	-17,2	-25,1
-98,5	-637,0		87,4	-98,5	-287,0	87,4	-8,6	-25,1
0,0	-637,0		87,4	0,0	-287,0	87,4	0,0	-25,1
98,5	-637,0		87,4	98,5	-287,0	87,4	8,6	-25,1
197,0	-637,0		87,4	197,0	-287,0	87,4	17,2	-25,1
totaal:						0,0	0,0	-252,7

Doorsnedeberekening

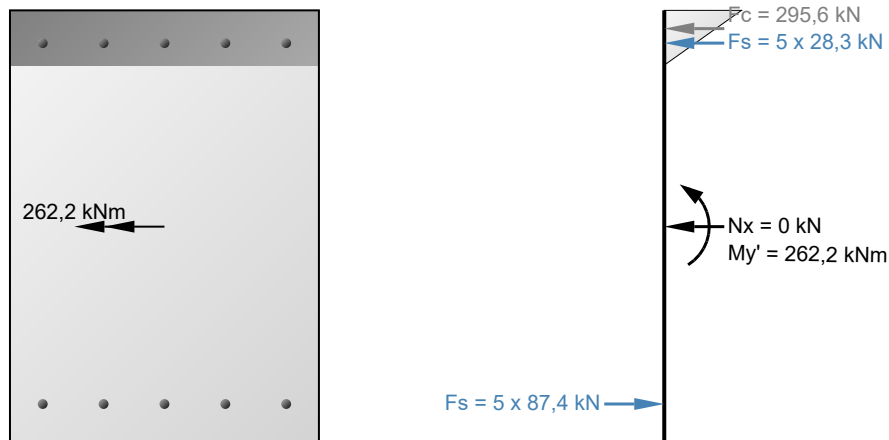
 $\epsilon_c = \epsilon_{c3}$ Hoek buigingsas en neutrale lijn $\alpha = 0,000^\circ$; $x_u = 88,7$ mm; $d = 637,0$ mmZwaartepunt doorsnede $y' = 0,0$ $z' = -350,0$ ($y = 0,0$ $z = 0,0$)

y' [mm]	z' [mm]	Wap.	A_s [mm ²]	$\Delta\epsilon$ [o/oo]	σ_c [N/mm ²]	$\Delta\sigma_s$ [N/mm ²]
0,0	0,0			-1,750	-13,3	
-197,0	-53,0	1Ø16	201	-0,704		-140,8
-98,5	-53,0	1Ø16	201	-0,704		-140,8
0,0	-53,0	1Ø16	201	-0,704		-140,8
98,5	-53,0	1Ø16	201	-0,704		-140,8
197,0	-53,0	1Ø16	201	-0,704		-140,8
-197,0	-637,0	1Ø16	201	10,822		434,8
-98,5	-637,0	1Ø16	201	10,822		434,8
0,0	-637,0	1Ø16	201	10,822		434,8
98,5	-637,0	1Ø16	201	10,822		434,8
197,0	-637,0	1Ø16	201	10,822		434,8

y' [mm]	z' [mm]	F_c [kN]	F_s [kN]	dy' [mm]	dz' [mm]	F [kN]	$F \cdot dy'$ [kNm]	$F \cdot dz'$ [kNm]
0,0	-29,6	-295,6		0,0	320,4	-295,6	0,0	-94,7
-197,0	-53,0		-28,3	-197,0	297,0	-28,3	5,6	-8,4
-98,5	-53,0		-28,3	-98,5	297,0	-28,3	2,8	-8,4
0,0	-53,0		-28,3	0,0	297,0	-28,3	0,0	-8,4
98,5	-53,0		-28,3	98,5	297,0	-28,3	-2,8	-8,4
197,0	-53,0		-28,3	197,0	297,0	-28,3	-5,6	-8,4
-197,0	-637,0		87,4	-197,0	-287,0	87,4	-17,2	-25,1
-98,5	-637,0		87,4	-98,5	-287,0	87,4	-8,6	-25,1
0,0	-637,0		87,4	0,0	-287,0	87,4	0,0	-25,1
98,5	-637,0		87,4	98,5	-287,0	87,4	8,6	-25,1
197,0	-637,0		87,4	197,0	-287,0	87,4	17,2	-25,1
totaal:						0,0	0,0	-262,2

Doorsnedeberekening

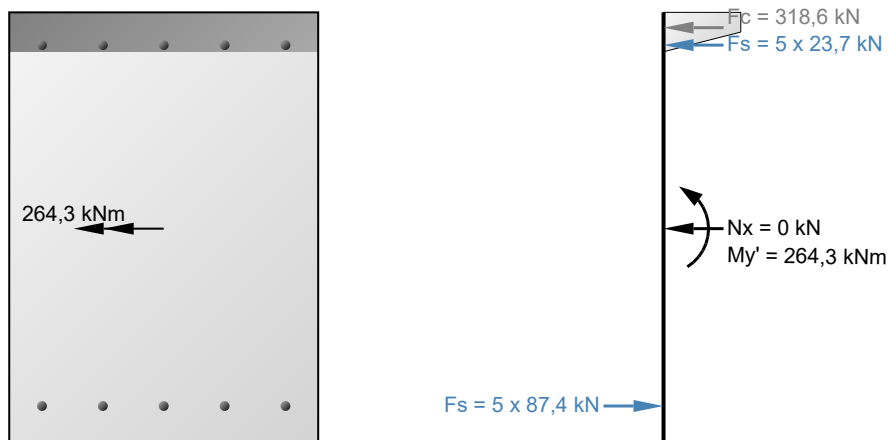
 $\epsilon_c = \epsilon_{cu3}$ Hoek buigingsas en neutrale lijn $\alpha = 0,000^\circ$; $x_u = 63,7$ mm; $d = 637,0$ mmZwaartepunt doorsnede $y' = 0,0$ $z' = -350,0$ ($y = 0,0$ $z = 0,0$)

y' [mm]	z' [mm]	Wap.	A_s [mm ²]	$\Delta\epsilon$ [o/oo]	σ_c [N/mm ²]	$\Delta\sigma_s$ [N/mm ²]
0,0	0,0			-3,500	-13,3	
-197,0	-53,0	1Ø16	201	-0,589		-117,8
-98,5	-53,0	1Ø16	201	-0,589		-117,8
0,0	-53,0	1Ø16	201	-0,589		-117,8
98,5	-53,0	1Ø16	201	-0,589		-117,8
197,0	-53,0	1Ø16	201	-0,589		-117,8
-197,0	-637,0	1Ø16	201	31,485		434,8
-98,5	-637,0	1Ø16	201	31,485		434,8
0,0	-637,0	1Ø16	201	31,485		434,8
98,5	-637,0	1Ø16	201	31,485		434,8
197,0	-637,0	1Ø16	201	31,485		434,8

y' [mm]	z' [mm]	F_c [kN]	F_s [kN]	dy' [mm]	dz' [mm]	F [kN]	$F \cdot dy'$ [kNm]	$F \cdot dz'$ [kNm]
0,0	-24,8	-318,6		0,0	325,2	-318,6	0,0	-103,6
-197,0	-53,0		-23,7	-197,0	297,0	-23,7	4,7	-7,0
-98,5	-53,0		-23,7	-98,5	297,0	-23,7	2,3	-7,0
0,0	-53,0		-23,7	0,0	297,0	-23,7	0,0	-7,0
98,5	-53,0		-23,7	98,5	297,0	-23,7	-2,3	-7,0
197,0	-53,0		-23,7	197,0	297,0	-23,7	-4,7	-7,0
-197,0	-637,0		87,4	-197,0	-287,0	87,4	-17,2	-25,1
-98,5	-637,0		87,4	-98,5	-287,0	87,4	-8,6	-25,1
0,0	-637,0		87,4	0,0	-287,0	87,4	0,0	-25,1
98,5	-637,0		87,4	98,5	-287,0	87,4	8,6	-25,1
197,0	-637,0		87,4	197,0	-287,0	87,4	17,2	-25,1
totaal:						0,0	0,0	-264,3

6.2 Dwarskracht / 6.3 Wringing

Ø10-150 (2sn.)

$$V_{Ed} = 100,00 \text{ kN} \quad T_{Ed} = 30,00 \text{ kNm}$$

$$k = 1 + \sqrt{\frac{200}{d}} = 1 + \sqrt{\frac{200}{637}} = 1,56 \leq 2,0$$

$$\rho_l = A_{sl} / (b_w d) = 1005 / (500 \times 637) = 0,003 < 0,02$$

$$V_{Rd,c} = [C_{Rd,c} k (100 \rho_l f_{ck})^{1/3} + k_1 \sigma_{cp}] b_w d = \dots(6.2.a)$$

$$= [0,12 \times 1,56 \times (100 \times 0,003 \times 20)^{1/3} + 0,15 \times 0] \times 500 \times 637 \times 10^{-3} = 110,217 \text{ kN}$$

$$v_{min} = 0,035 k^{3/2} f_{ck}^{1/2} = 0,035 \times 1,56^{3/2} \times 20^{1/2} = 0,305 \text{ N/mm}^2 \dots(6.3N)$$

$$V_{Rd,c} = (v_{min} + k_1 \sigma_{cp}) b_w d = (0,305 + 0,15 \times 0) \times 500 \times 637 \times 10^{-3} = 97,17 \text{ kN} \dots(6.2.b)$$

$$A = b h = 500 \times 700 = 350000 \text{ mm}^2 \quad u = 2 b + 2 h = 2 \times 500 + 2 \times 700 = 2400 \text{ mm}$$

$$t_{ef,i} = A / u = 350000 / 2400 = 146 \text{ mm}$$

$$A_k = (b - \frac{1}{2} t_{ef,i} - \frac{1}{2} t_{ef,i}) (h - \frac{1}{2} t_{ef,i} - \frac{1}{2} t_{ef,i}) =$$

$$= (500 - \frac{1}{2} \times 146 - \frac{1}{2} \times 146) \times (700 - \frac{1}{2} \times 146 - \frac{1}{2} \times 146) = 196267 \text{ mm}^2$$

$$T_{Rd,c} = 2 A_k \tau_{T,i} t_{ef,i} = 2 \times 196267 \times 1,03 \times 146 = 59,05 \text{ kNm} \dots(6.26)$$

$$\frac{T_{Ed}}{T_{Rd,c}} + \frac{V_{Ed}}{V_{Rd,c}} = \frac{30}{59,05} + \frac{100}{110,217} = 1,42 > 1,00 \dots(6.31)$$

$$v = 0,6 \left[1 - \frac{f_{ck}}{250} \right] = 0,6 \times \left[1 - \frac{20}{250} \right] = 0,552 \dots(6.6N)$$

$$V_{Rd,max} = \alpha_{cw} b_w z v_1 f_{cd} / (\cot \theta + \tan \theta) \dots(6.9)$$

$$= 1 \times 500 \times 573 \times 0,6 \times 13,3 / (1,192 + 0,839) = 1129,18 \text{ kN}$$

$$v = 0,6 \left[1 - \frac{f_{ck}}{250} \right] = 0,6 \times \left[1 - \frac{20}{250} \right] = 0,552 \dots(6.6N)$$

$$T_{Rd,max} = 2 v_1 \alpha_{cw} f_{cd} A_k t_{ef,i} \sin \theta \cos \theta \dots(6.30)$$

$$= 2 \times 0,55 \times 1 \times 13,333 \times 196267 \times 145,8 \times 0,643 \times 0,766 = 207,46 \text{ kNm}$$

$$\frac{T_{Ed}}{T_{Rd,max}} + \frac{V_{Ed}}{V_{Rd,max}} = \frac{30}{207,46} + \frac{100}{1129,181} = 0,23 < 1,00 \dots(6.29)$$

$$\frac{A_{sw}}{s} = \frac{V_{Ed}}{f_{ywd} z \cot \theta} = \frac{100}{435 \times 573 \times 1,192} = 0,337 \text{ mm}^2/\text{mm} \dots(6.8)$$

$$\rho_{w,min} = (0,08 * \sqrt{f_{ck}}) / f_{yk} = 0,00072 \dots(9.5N)$$

$$\frac{A_{sw,min}}{s} = \rho_{w,min} b_w = 0,00072 \times 500 = 0,358 \text{ mm}^2/\text{mm}$$

$$\frac{A_{sw}}{s} = \frac{T_{Ed} \tan \theta}{2 b_1 h_1 f_{ywd}} = \frac{30 \times 0,839}{2 \times 354 \times 554 \times 435} = 0,147 \text{ mm}^2/\text{mm}$$

$$A_{s,l} = \frac{T_{Ed} \cotan \theta u_k}{f_{ywd} 2 A_k} = \frac{30 \times 1,192 \times 1817}{435 \times 2 \times 196267} = 381 \text{ mm}^2 \quad \dots(6.28)$$

AswV = 0,179 mm²/mm AsT = 0,147 mm²/mm Asw_ben = 0,326 mm²/mm
 Asw_ben = 0,326 mm²/mm < Asw_aanw = 0,524 mm²/mm (u.c.=0,62)

Hoofdstuk 7 Bruikbaarheidsgrenstoestanden (BGT)

7.3.3 Scheurbeheersing zonder directe berekening

$$M_k = 122,00 \text{ kNm} < M_{Rk} = 141,49 \text{ kNm} \quad (\text{u.c.}=0,86)$$

$$\sigma_s = 241,2 \text{ N/mm}^2 \quad w_k = 0,2 \text{ mm} \rightarrow$$

$$s_{\max} = 99 \text{ mm}$$

...(Tabel 7.3N)

$$s_{\text{prov}} = 98,5 \text{ mm} \leq s_{\max} = 98,5 \text{ mm}$$

Doorsnedeberkening

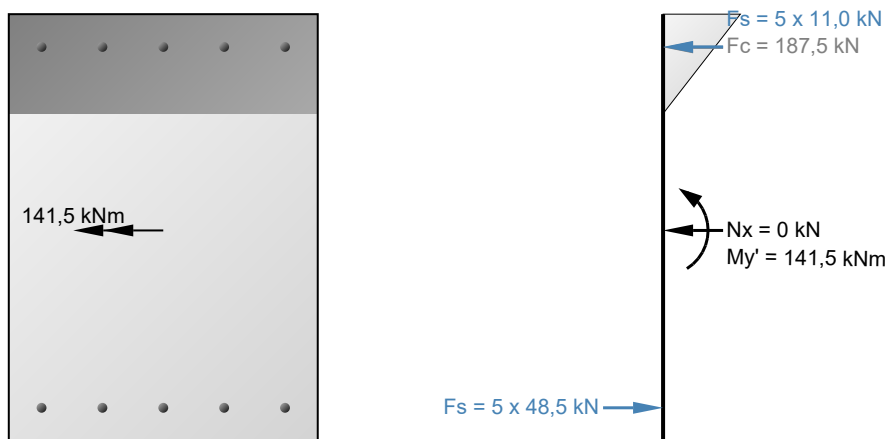

Hoek buigingsas en neutrale lijn $\alpha = 0,000^\circ$; $x_u = 160,9 \text{ mm}$; $d = 637,0 \text{ mm}$
 Zwaartepunt doorsnede $y' = 0,0$ $z' = -350,0$ ($y = 0,0$ $z = 0,0$)

y' [mm]	z' [mm]	Wap.	A_s [mm ²]	$\Delta\varepsilon$ [o/oo]	σ_c [N/mm ²]	$\Delta\sigma_s$ [N/mm ²]
0,0	0,0			-0,408	-4,7	
-197,0	-53,0	1Ø16	201	-0,273		-54,7
-98,5	-53,0	1Ø16	201	-0,273		-54,7
0,0	-53,0	1Ø16	201	-0,273		-54,7
98,5	-53,0	1Ø16	201	-0,273		-54,7
197,0	-53,0	1Ø16	201	-0,273		-54,7
-197,0	-637,0	1Ø16	201	1,206		241,2
-98,5	-637,0	1Ø16	201	1,206		241,2
0,0	-637,0	1Ø16	201	1,206		241,2
98,5	-637,0	1Ø16	201	1,206		241,2
197,0	-637,0	1Ø16	201	1,206		241,2

y' [mm]	z' [mm]	Fc [kN]	Fs [kN]	dy' [mm]	dz' [mm]	F [kN]	F.dy' [kNm]	F.dz' [kNm]
0,0	-53,6	-187,5		0,0	296,4	-187,5	0,0	-55,6
-197,0	-53,0		-11,0	-197,0	297,0	-11,0	2,2	-3,3
-98,5	-53,0		-11,0	-98,5	297,0	-11,0	1,1	-3,3
0,0	-53,0		-11,0	0,0	297,0	-11,0	0,0	-3,3
98,5	-53,0		-11,0	98,5	297,0	-11,0	-1,1	-3,3
197,0	-53,0		-11,0	197,0	297,0	-11,0	-2,2	-3,3
-197,0	-637,0		48,5	-197,0	-287,0	48,5	-9,6	-13,9
-98,5	-637,0		48,5	-98,5	-287,0	48,5	-4,8	-13,9
0,0	-637,0		48,5	0,0	-287,0	48,5	0,0	-13,9
98,5	-637,0		48,5	98,5	-287,0	48,5	4,8	-13,9
197,0	-637,0		48,5	197,0	-287,0	48,5	9,6	-13,9
totaal:						0,0	0,0	-141,5

Conclusie: Doorsnede voldoet.